

## 48224873 Emporia MB-302 T2

- 3~230/400 V
- 50 Hz
- Thermischer Überlastungsschutz
- Thermische Klasse F
- Schutzart IP44
- 2-stufige Blockbauweise

### Kennlinien:

Emporia MB-101, 152, 202, 302,  $n = 2900 \text{ min}^{-1}$

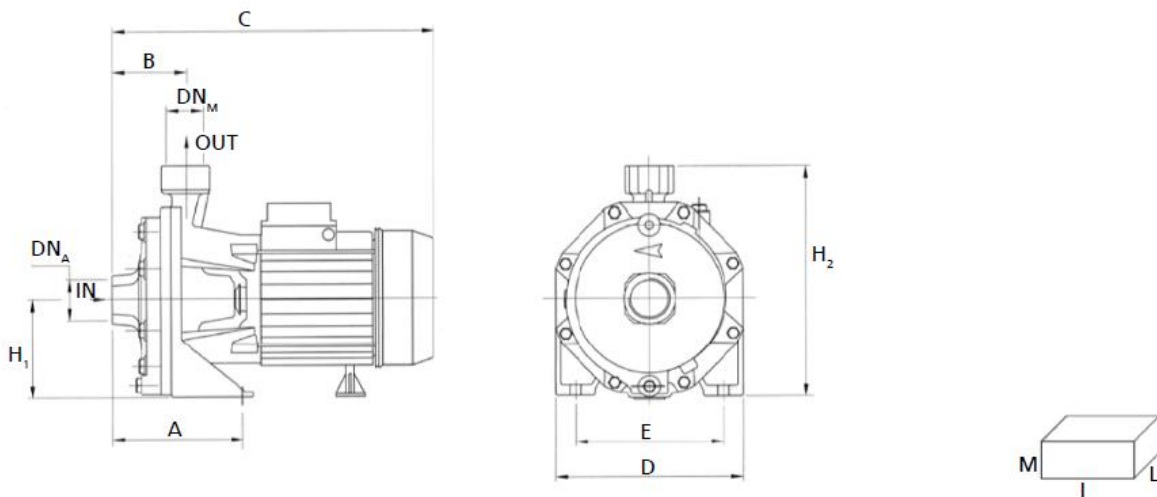
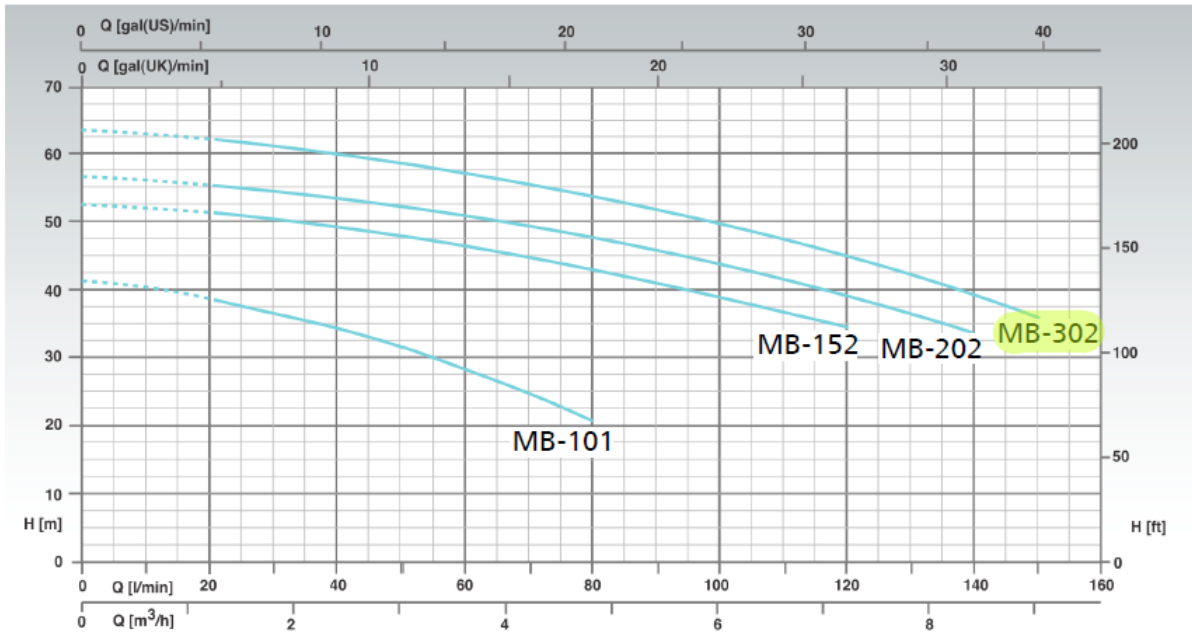

Abb. 1: Emporia MB

Abmessungen [mm]

Baugröße	DN <sub>A</sub>	DN <sub>M</sub>	A	B	C	D	E	F	H <sub>1</sub>	H <sub>2</sub>	I	L	M
MB-302	G 1 1/4	G 1	115	82	385	210	170	110	265	405	405	225	295