

Amamix C 4138/38 UDG

Tank

Liquid volume	365.40 m ³	Fill level	7.00 m
Material	Concrete	Basin length	8.70 m
Tank shape	Rectangular tank (E)	Basin width	6.00 m

Installation parts

Scope of supply	Mixer with installation parts	Length	1.50 m
Type of Installation	Universal Instalation (Accessories 22)	Holder for square guide rail	Yes
considered mounting depth (guide tube length)	7.00 m	Claw material	Stainless steel 1.4571
Material guide tube	Stainless steel 1.4301	Bracket	Yes
Guide tube 1	60 x60 x3	Additional fastening set lower holder	Adjustable (universal) level tank floor
Quantity	1	Number of center supports	1
Length	6.00 m	Adapter for tilt adjustment	universal
Guide tube 2	60 x60 x3		
Quantity	1		

Material variant

Axial propeller (ECB)	Stainless steel 1.4571	Motor housing	Grey cast iron EN-GJL-250
Gear casing		Shaft	Stainless steel 1.4571
Jet pipe	Without	Studs	A4
Gasket	FKM 80		

Medium

Pumped medium	Sludge Activated sludge (agitator) Not containing chemical and mechanical substances which affect the materials	Dry substance content [DS]	1.00 %
		Loss on ignition	70.00 %
		Sludge volume index (SVI)	80.00 ml/g
		Viscosity	1.00 mPa s
		Share rate	189.00 1/s
Density	1000 kg/m ³		
Operating temperature	20.0 °C		

Creation of flow

Average flow velocity required	30.00 cm/s	The average flow velocity can only be achieved if inflows are oriented in flow direction.
Calculated minimum average flow velocity	30.00 cm/s	

Design

Max. temperature	40.0 °C	Manufacturer	KSB
weight	91 kg	Type (propeller side)	MG
Type	Amamix C 4138 / 3 8	Material code (propeller side)	SIC/SIC/FPM
Execution of drive	direct	Mixer standard	KSB-Aggregate international execution
Number of blades	3		
Propeller diameter	410.0 mm		
Propeller speed	700 rpm	Ex protection	No
Absorbed power P1 at operating point based on pure water	2.98 kW	Norm	Without
Shaft seal	2 mech. seals in tandem arrangement with oil reservoir	Temperature classes aggregate	without
Sealing plan	T Tandem mechanical seal	additional leakage control	Without
		Weight	91

Amamix C 4138/38 UDG

Please note

KSB quotations and the selection of mixers are exclusively based on the operating parameters specified above as well as the relevant physical variables. Consequently, KSB only accepts warranty obligations for the mixing equipment to the extent of the data provided. It is therefore important that the customer verifies whether the system data considered by KSB in the mixer data sheet does, in fact, conform with the data of the application, and that KSB is informed of any deviations. As the overall function substantially depends on the correct positioning of the mixing equipment, KSB does not accept any warranty claims resulting from a mixer positioning which has not explicitly been approved of by us. Neither low-flow areas (flow separation) resulting from the tank geometry nor the hydraulic solids transportation of the overall system are subject to the KSB warranty. Furthermore, the utilisation of KSB mixers in protected procedures, and any resultant infringement of the industrial property rights of third parties, are similarly excluded.

Possible unexpected on-site conditions may result in the reduction of the average flow velocity. In addition, tolerances in the average flow velocity may occur when conforming with the mixer-relevant standards and directives.

Please observe that velocities higher than the average flow velocity may be present locally.

The required flow velocity for a sediment-free operation is determined by the operational quality of the systems upstream of the tank, essentially by the quantity of solids reaching the tank. Activated sludge flocs settle at flow velocities < 10 cm/s or in case of lack of local turbulence.

Without addition of polymeric flocculation aid.

Mixer(s) positioning in accordance with the system drawing!

Motor

FI operation permitted	Yes (acc. motor manufacturer)	Motor moisture sensor	1
Driver type	Electric motor	Frequency	50 Hz
Motor manufacturer	KSB	Motor speed	700 rpm
Motor generation	D	Rated current	6.9 A
Motor supplied by	Standard motor supplied by KSB - mounted by KSB	Starting current ratio	3.5
Efficiency class	not classified	Insulation class	F to IEC 34-1
Rated voltage	400 V	Poles	8
Rated power	2.50 kW	Starting mode	Direct/Star-delta possible
Type of protection	Without	Operation with Frequency Inverter.	No
Motor enclosure	IP68	Cable design	Rubber hose
Temperature classes	without	Cable entry	Sealed along entire length
Temperature sensor	PTC resistor	Sales description power cable	S1BN8-F 12G1.5
Winding	400 / 690 V	Number of power cables	1
Connection mode	Delta	Cable length	10.00 m
Cooling method	Surface cooling	Number of additional cable support including catch hook	0
Motor version	U		

Nameplates

Nameplates language	International	Duplicate nameplate	With
---------------------	---------------	---------------------	------

Packaging

IPPC Standard ISPM 15	Yes	Packaging for transport	Truck
Packaging category	B1 Wooden or plywood case, cover provided with polypropylene cellular sheet, outdoor storage up to 3 months	Outdoor storage at -40°C to +50°C for up to 3 months. Packet must be covered. No corrosion protection, only transport protection.	
Packaging for storage	Indoor		

Amamix C 4138/38 UDG

PEDESTAL DKBV-O.VBA-215632

socket for floor mounting for crans 250kg; 360kg; 550k,
material galv.
Steel

Material no 01615696

ROPE 5X12000

lifting rope for cranes, remains with the unit, for use with
transportable crane, diameter=5mm; lenght 12m ; material
1.4401

Material no 11304621

HOLDER SEILSPANNER DM.5

tightener and snubbing post for rope; material 1.4571

Material no 19554260

CRANE 250/2000-231173

Crane, carrying capacity 250 kg with a working range of max.
2046 mm,
incl. installation set; material galvanized steel with rope
winch,
carrying capacity max. 500 kg, rope 12 m; material galvanized
steel

Material no 01615688

Amamix C 4138/38 UDG

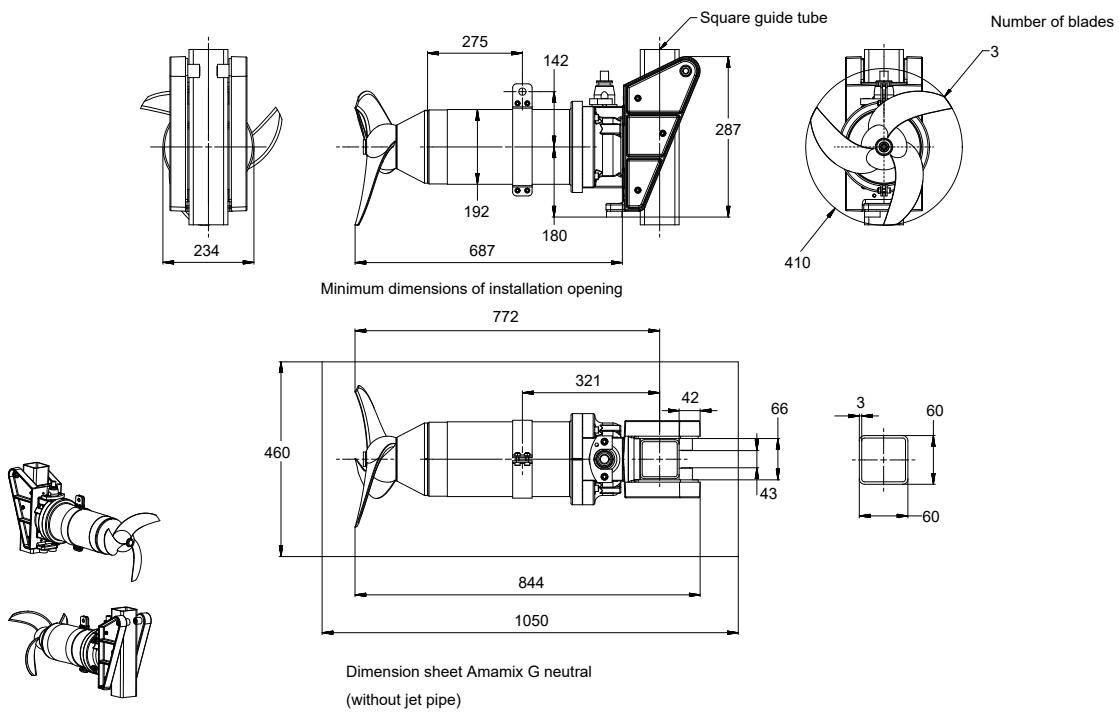

Drawing is not to scale

Dimensions in mm

Amamix C 4138/38 UDG

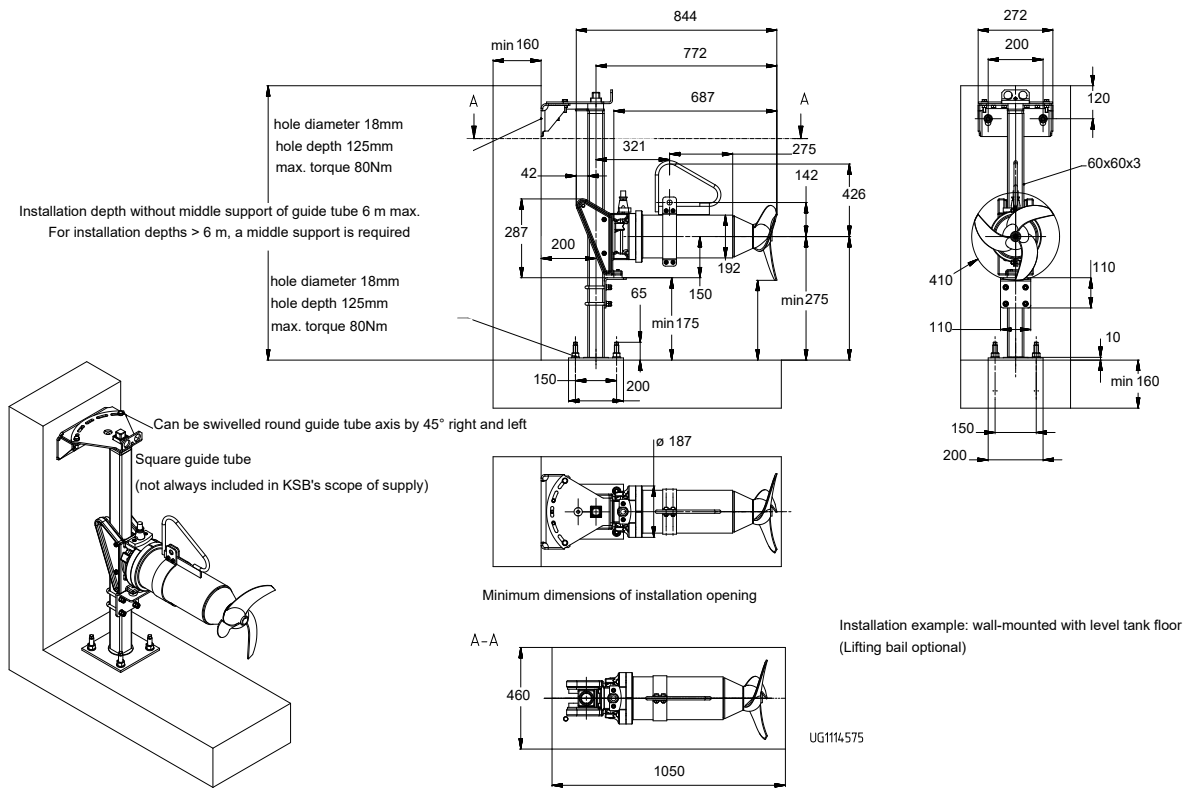

Drawing is not to scale

Dimensions in mm

Universal Instalation (Accessories 22)

Amamix C 4138/38 UDG

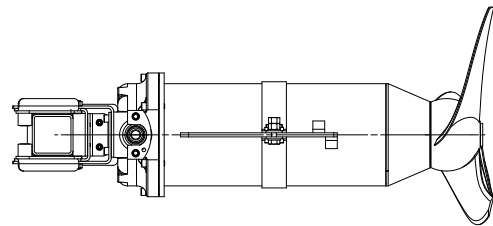
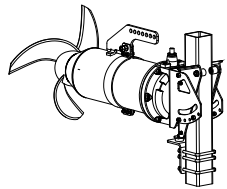
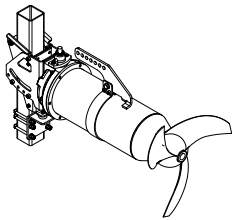
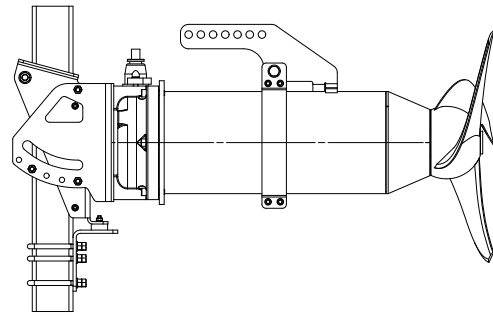
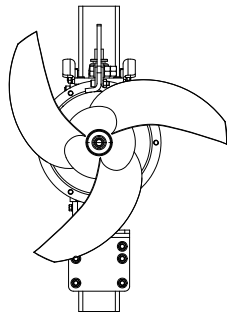

UG1289963

Drawing is not to scale

Adapter for tilt adjustment

Amamix C 4138/38 UDG

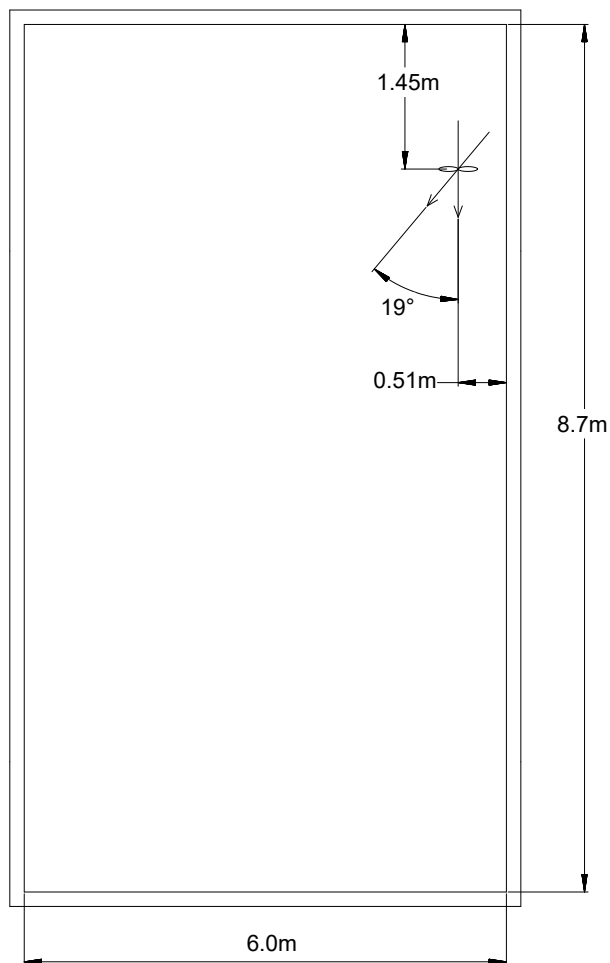

Drawing is not to scale

The propeller centre is the reference point.

Tank shape: Rectangular tank (E)
Type of Installation: Wall mounting

RW1: Amamix C 4138/38 UDG

Comments

Tank installations are not shown in the positioning options. Please check whether the positioning is suitable for the local conditions.