

Etabloc 100-080-160 GG
 ETB 100-080-160-GGSBV11 WSEEO2HHB

Operating point 1 Dimensioning operating point

Operating conditions (purchaser requirements)

Target flow rate	140 m ³ /h	Vapour pressure determined	0,02337 bar.a
Target head	27 m	Minimum inlet pressure required	-0,2759 bar.r
Fluid	Water	Specified ambient temperature	20 °C
Fluid variant	Clean water	Installation altitude above sea level	1.000 m
Specified fluid temperature	20 °C		
Density Fluid handled	998 kg/m ³		
Kinematic viscosity Fluid handled	1 mm ² /s		

Operating conditions (performance)

Flow rate	140,14 m ³ /h	Maximum power input at duty point	13,99 kW
Minimum permissible flow rate	31,57 m ³ /h	Maximum power input / curve	15,89 kW
Head	27,05 m	Pump speed	2.960 1/min
Shut-off head	30,78 m	Discharge pressure-max.	3,012 bar.r
Efficiency Pump	73,71 %		
NPSH required	6,66 m		

Design data pump

Scope of supply Pump supplied by KSB	Pump + motor	Input voltage and frequency	Without
Pump standard	EN 733	Mains voltage	400 V
Shaft axis position	Horizontal	Mains frequency	50 Hz
Pump design	Close-coupled	Minimum efficiency index MEI	0,7
Pump system design	Single-pump system	Minimum permissible fluid temperature	0 °C
Specification of wetted parts	Manufactured without paint wetting impairment substances	Maximum permissible fluid temperature	60 °C
Pump direction of rotation, viewed from casing side	Counterclockwise	Quantity Stages, single-entry	1
Impeller diameter D2	152 mm	Casing wear ring design suction-side	Flat
Impeller type	Radial, closed, multi-channel	Casing wear ring design discharge-side	Flat
Free passage	15,1 mm	Installation chamber Casing cover	Conical (A-type cover)
Nut lock for Impeller	No	Bearing bracket size / shaft unit	25
Swirl break	No	Pump bearing type, non-drive end	Anti-friction bearing
Support foot	No	Pump bearing type, drive end	Anti-friction bearing
		Pump directive	CE

Etabloc 100-080-160 GG
 ETB 100-080-160-GGSBV11 WSEEO2HHB

Nozzle connections pump

Nominal diameter Suction nozzle	DN 100	Nominal diameter Discharge nozzle	DN 80
Nominal pressure Suction nozzle	PN 16	Nominal pressure Discharge nozzle	PN 16
Suction nozzle position	Axial	Discharge nozzle position	0 deg
Suction nozzle design acc.to	EN1092-2	Discharge nozzle design acc.to	EN1092-2
Suction flange bolt hole pattern as per standard	EN1092-2	Discharge flange bolt hole pattern as per standard	EN1092-2
Flange facing type Inlet	Raised face (B,RF)		
Flange facing type Outlet	Raised face (B,RF)		

Auxiliary connections pump

6B Fluid Drain	G 3/8 Drilled and plugged	1M Pressure gauge Discharge nozzle	Without Without
6D Fluid Filling and venting	G 3/8 Drilled and plugged	1M Pressure gauge Suction nozzle	Without Without
5B Venting and drain	G 1/4 Drilled and plugged		

Shaft sealing

Shaft seal type	SMS A-type cover, vented	Shaft seal code	Code 11
Operating mode of mechanical seal (function)	API plan 03	Shaft seal manufacturer inboard	KSB's choice
Determined pressure Seal chamber	-0,1 bar.r	Mechanical seal type inboard	1
		Material Shaft seal inboard	BQ1EGG-WA

Materials

Material Volute casing (102)	EN-GJL-250/A48 CL 35B	Material Bolts/Screws Volute casing (902.01)	8.8
Material Casing cover (161)	EN-GJL-250/A48 CL 35B	Material Screw plug Volute casing (903.01)	ST
Material Shaft	C45+N	Material Static seal Screw plug Volute casing	A4/AISI 316
Material Impeller (230)	EN-GJL-250/A48 CL 35B	Material Nut Impeller fastening (920.95)	(ST)
Material Casing wear ring suction-side (502.01)	JL/LAMELLAR GRAPHITE CAST IRON	Material Key	C45+C/A311 GR 1045 CLASS A
Material Casing wear ring discharge-side (502.02)	JL/LAMELLAR GRAPHITE CAST IRON		
Material Shaft protecting sleeve (523)	(CRNIMO ST INT)		
Material Static seal Discharge cover	DPAF DW001		
Material Drive lantern	EN-GJL-250/A48 CL 35B		

Etabloc 100-080-160 GG
 ETB 100-080-160-GGSBV11 WSEEO2HHB

Driver

Electric motor	Yes	Rated speed Motor	2.945 1/min
Drive concept	Electric actuator	Number of motor poles	2
Drive standard, mechanical	IEC	Rated power Motor	18,5 kW
Drive standard electric	IEC	Motor power reserve determined	32,3 %
Motor bearing, insulated	No	Rated voltage Motor	400 V
Motor manufacturer	KSB's choice	Motor winding	400 / 690 V
Customer supply Drive	No	Rated frequency Motor	50Hz
Motor construction type	IM V15 (IM2011) IEC 60034-7	Motor switching type	Delta
Motor size	160L	Rated current Motor	35,6 A
Efficiency class	IE3 (Premium)	Starting current ratio Ia/In	9,5
Material motor housing	AL	Cos phi at 4/4 load	0,77
Enclosure Motor	IP55	Motor efficiency at 4/4 load	92,4 %
Enclosure Unit	Without	Directive Drive	CE
Thermal class	155 (F) nach IEC 60085		
Temperature sensor motor	3 PTC thermistors		
Terminal box position of motor (looking at the motor shaft)	360 Grad		
Operation on a frequency inverter permitted	Yes (acc to motor manufact)		
Sound pressure level Motor	74 dBa		
Type series Motor manufacturer	Acc. to motor manufacturer		

Coating

Aggregate

Surface preparation	Free from dirt, grease, rust
Properties Primer coat	Hydro dip primer, water-dilutable
Thickness Primer coat	60 µm
Properties Top coat	Acrylate dispersion water-thinned
Thickness Top coat	40 µm
Colour Top coat	RAL5002 Ultramarine Blue

Packaging

Suitable for transport	Sea freight
Suitable for storage	Indoor storage
Packaging category	Wooden box for outdoor storage, with desiccant, water vapour proof PE film seal (B02)
IPPC Standard ISPM 15	Yes

Nameplates

Duplicate name plate	No
----------------------	----

Performance Curve (Pump)



Etabloc 100-080-160 GG ETB 100-080-160-GGSBV11 WSEEO2HHB

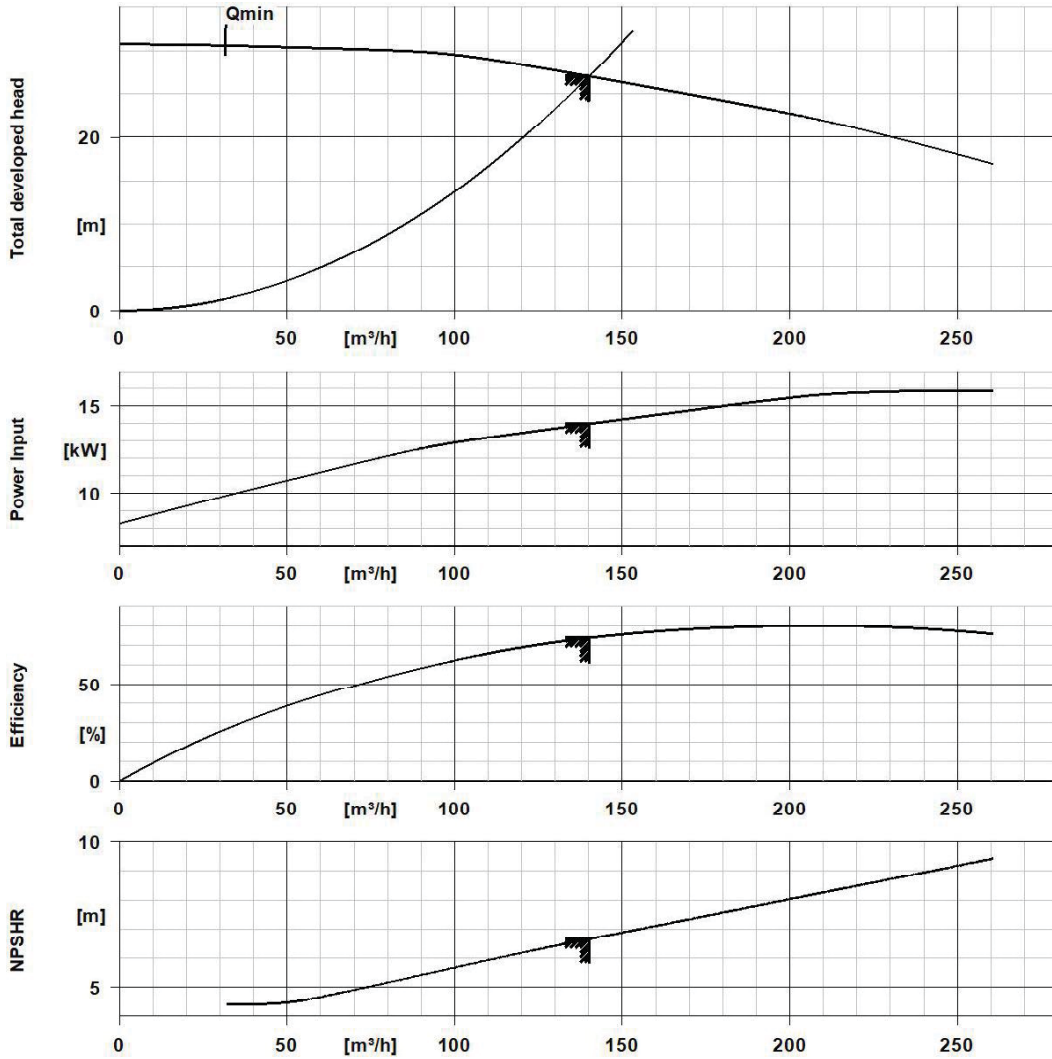

Curve Data

Pump speed	2.960 1/min	Efficiency Pump	73,7 %
Density Fluid handled	998 kg/m ³	Minimum efficiency index MEI	0,7
Kinematic viscosity Fluid handled	1 mm ² /s	Maximum power input at duty point	14 kW
Flow rate	140 m ³ /h	NPSH required	6,66 m
Head	27,1 m	Hydraulic impeller diameter	151,7 mm
		Hydraulic calculation according to standard/class	EN ISO 9906 Class 3B

Etabloc 100-080-160 GG
 ETB 100-080-160-GGSBV11 WSEEO2HHB

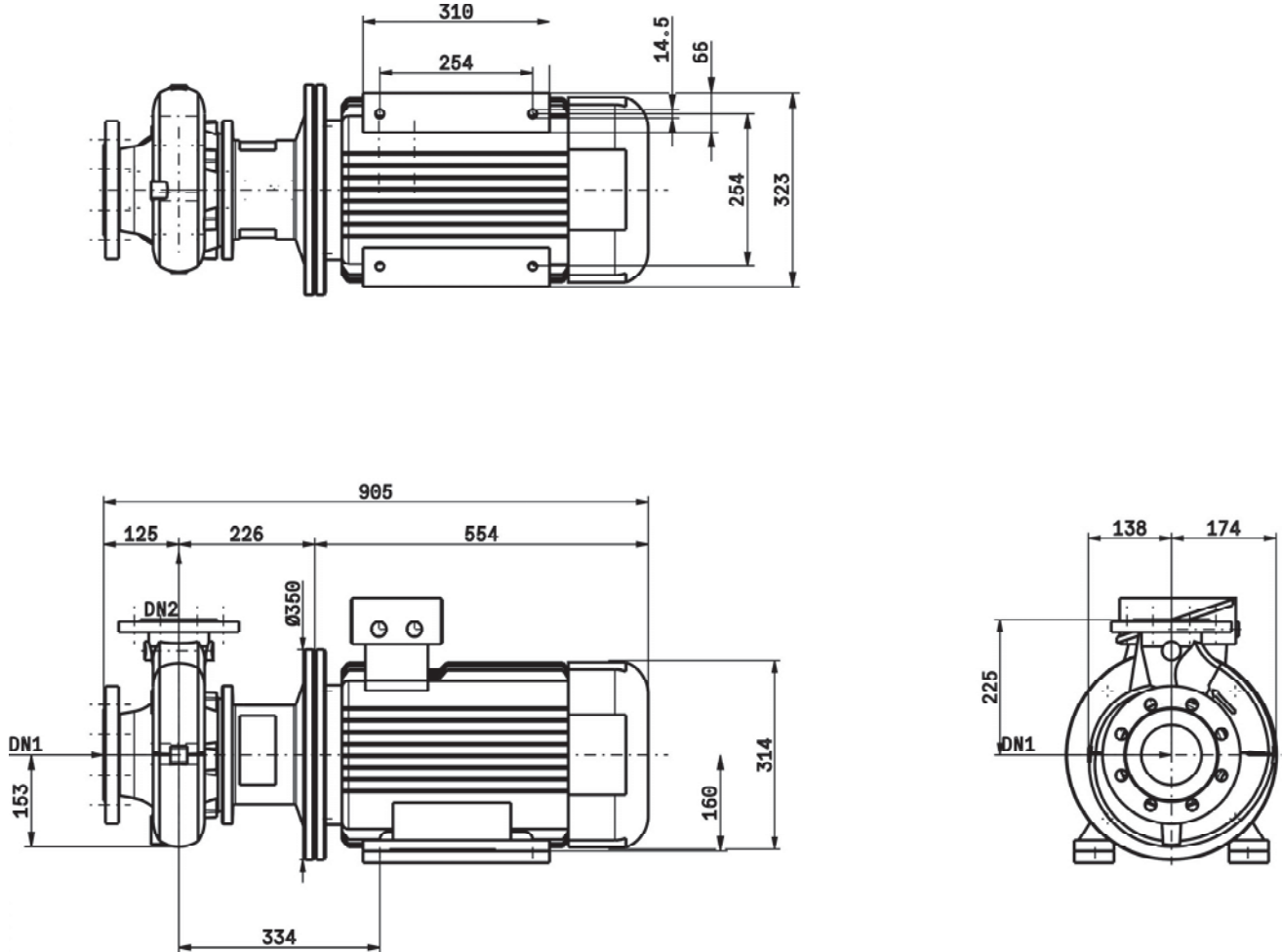

Drawing is not to scale.

Dimensions are given in mm

Motor

Motor manufacturer	KSB's choice
Motor size	160L
Rated power Motor	18,5 kW
Number of motor poles	2
Rated speed Motor	2.945 1/min
Terminal box position of motor (looking at the motor shaft)	360 Grad

Connections

Nominal diameter Suction nozzle	DN 100
Suction flange bolt hole pattern as per standard	EN1092-2
Nominal diameter Discharge nozzle	DN 80
Discharge flange bolt hole pattern as per standard	EN1092-2
Nominal pressure Suction nozzle	PN 16
Nominal pressure Discharge nozzle	PN 16

Net weight

Total weight Pump	55,45 kg
Total weight Drive	108 kg
Total weight Pump set	163,5 kg



Etabloc 100-080-160 GG

ETB 100-080-160-GGSBV11 WSEEO2HHB

Connect pipelines stress-free

Dimensional tolerances for shaft axis height: DIN 747

Dimensions without tolerances, middle tolerances to: ISO 2768-m

Connection dimensions for pumps: EN735

Dimensions without tolerances - welded parts: ISO 13920-B

Dimensions without tolerances - gray cast iron parts: ISO 8062-CT9

Plan for additional connections see extra drawing