

Etabloc 080-065-315 GB

ETB 080-065-315-GBKBV11 WSFDN4HHB

Operating point 1

Dimensioning operating point

Operating conditions (purchaser requirements)

Target flow rate	60 m ³ /h
Target head	25 m
Fluid	Water, drinking water / tap water
Fluid variant	without further specification
	50746
Specified fluid temperature	20 °C
Density Fluid handled	998 kg/m ³
Kinematic viscosity Fluid handled	1 mm ² /s

Vapour pressure determined	0,02337 bar.a
Minimum inlet pressure required	-0,3 bar.r
Specified ambient temperature	20 °C
Installation altitude above sea level	1.000 m

Operating conditions (performance)

Flow rate	60,02 m ³ /h
Minimum permissible flow rate	10,22 m ³ /h
Head	25,02 m
Shut-off head	28,54 m
Efficiency Pump	70,96 %
NPSH required	1,38 m

Maximum power input at duty point	5,754 kW
Maximum power input / curve	7,047 kW
Pump speed	1.474 1/min
Discharge pressure-max.	2,793 bar.r

Etabloc 080-065-315 GB
 ETB 080-065-315-GBKBV11 WSFDN4HHB

Design data pump

Scope of supply Pump supplied by KSB	Pump + motor	Input voltage and frequency	Without
Pump standard	EN 733	Mains voltage	400 V
Design according to regulation	Drinking water	Mains frequency	50 Hz
Shaft axis position	Horizontal	Minimum efficiency index MEI	0,7
Pump design	Close-coupled	Minimum permissible fluid temperature	0 °C
Pump system design	Single-pump system	Maximum permissible fluid temperature	60 °C
Specification of wetted parts	Manufactured without paint wetting impairment substances	Quantity Stages, single-entry	1
Pump direction of rotation, viewed from casing side	Counterclockwise	Casing wear ring design suction-side	Flat
Impeller diameter D2	278 mm	Casing wear ring design discharge-side	Flat
Impeller type	Radial, closed, multi-channel	Installation chamber Casing cover	Conical (A-type cover)
Free passage	13 mm	Bearing bracket size / shaft unit	35
Support foot	No	Pump bearing type, non-drive end	Anti-friction bearing
		Pump bearing type, drive end	Anti-friction bearing
		Pump directive	CE
		Marking according to directive Pump/Valve for destination country	Not relevant
		Explosion protection directive Pump/Valve for destination country	Not relevant

Nozzle connections pump

Nominal diameter Suction nozzle	DN 80	Nominal diameter Discharge nozzle	DN 65
Nominal pressure Suction nozzle	PN 16	Nominal pressure Discharge nozzle	PN 16
Suction nozzle position	Axial	Discharge nozzle position	0 deg
Suction nozzle design acc.to	EN1092-2	Discharge nozzle design acc.to	EN1092-2
Suction flange bolt hole pattern as per standard	EN1092-2	Discharge flange bolt hole pattern as per standard	EN1092-2
Flange facing type Inlet	Raised face (B,RF)		
Flange facing type Outlet	Raised face (B,RF)		

Etabloc 080-065-315 GB

ETB 080-065-315-GBKBV11 WSFDN4HHB

Auxiliary connections pump

6B Fluid Drain	G 3/8 Drilled and plugged	1M Pressure gauge Discharge nozzle	G 3/8 Drilled and plugged
6D Fluid Filling and venting	G 3/8 Drilled and plugged	1M Pressure gauge Suction nozzle	G 3/8 Drilled and plugged
5B Venting and drain	G 1/4 Drilled and plugged		

Shaft sealing

Shaft seal type	SMS A-type cover, vented	Shaft seal code	Code 11
Operating mode of mechanical seal (function)	API plan 03	Shaft seal manufacturer inboard	KSB's choice
Determined pressure Seal chamber	-0,14 bar.r	Mechanical seal type inboard	KSB's choice
		Material Shaft seal inboard	BQEGG DW001

Variant shaft seal

Materials

Material Volute casing (102)	EN-GJL-250/A48 CL 35B	Material Bolts/Screws Volute casing (902.01)	8.8
Material Casing cover (161)	EN-GJL-250/A48 CL 35B	Material Nut Impeller fastening (920.95)	(CRNIMO ST INT)
Material Shaft	C45+N		
Material Impeller (230)	CC480K DW		
Material Casing wear ring suction-side (502.01)	JL/LAMELLAR GRAPHITE CAST IRON		
Material Casing wear ring discharge-side (502.02)	JL/LAMELLAR GRAPHITE CAST IRON		
Material Shaft protecting sleeve (523)	(CRNIMO ST INT)		
Material Static seal Discharge cover	DPAF DW001		
Material Drive lantern	EN-GJL-250/A48 CL 35B		

Etabloc 080-065-315 GB

ETB 080-065-315-GBKBV11 WSFDN4HHB

Driver

Electric motor	Yes	Rated speed Motor	1.465 1/min
Drive concept	Electric actuator	Number of motor poles	4
Drive standard, mechanical	IEC	Rated power Motor	7,5 kW
Drive standard electric	IEC	Motor power reserve determined	30,4 %
Motor bearing, insulated	No	Rated voltage Motor	400 V
Motor manufacturer	KSB's choice	Motor winding	400 / 690 V
Customer supply Drive	No	Rated frequency Motor	50Hz
Motor construction type	IM V15 (IM2011) IEC 60034-7	Motor switching type	Delta
Motor size	132M	Rated current Motor	15 A
Efficiency class	IE3 (Premium)	Starting current ratio Ia/In	8,9
Material motor housing	AL	Cos phi at 4/4 load	0,8
Enclosure Motor	IP55	Motor efficiency at 4/4 load	90,4 %
Enclosure Unit	Without	Explosion protection directive Drive for destination country	Not relevant
Thermal class	155 (F) nach IEC 60085	Limit value Maximum humidity Motor	30 g/m ³
Temperature sensor motor	3 PTC thermistors	Marking according to directive Drive	CE
Terminal box position of motor (looking at the motor shaft)	360 °	Marking according to directive Drive for destination country	Not relevant
Operation on a frequency inverter permitted	Yes (acc to motor manufact)		
Sound pressure level Motor	67 dBa		
Type series Motor manufacturer	Acc. to motor manufacturer		

Coating

Aggregate

Surface preparation	Free from dirt, grease, rust
Properties Primer coat	Hydro dip primer, water-dilutable
Thickness Primer coat	60 µm
Properties Top coat	Acrylate dispersion water-thinned
Thickness Top coat	40 µm
Colour Top coat	RAL5002 Ultramarine Blue

Packaging

Suitable for transport	Truck transport
Suitable for storage	Indoor storage
Packaging category	KSB's choice (A0)

Nameplates

Duplicate name plate	No
----------------------	----

Performance Curve (Pump)



Etabloc 080-065-315 GB ETB 080-065-315-GBKBV11 WSFDN4HHB

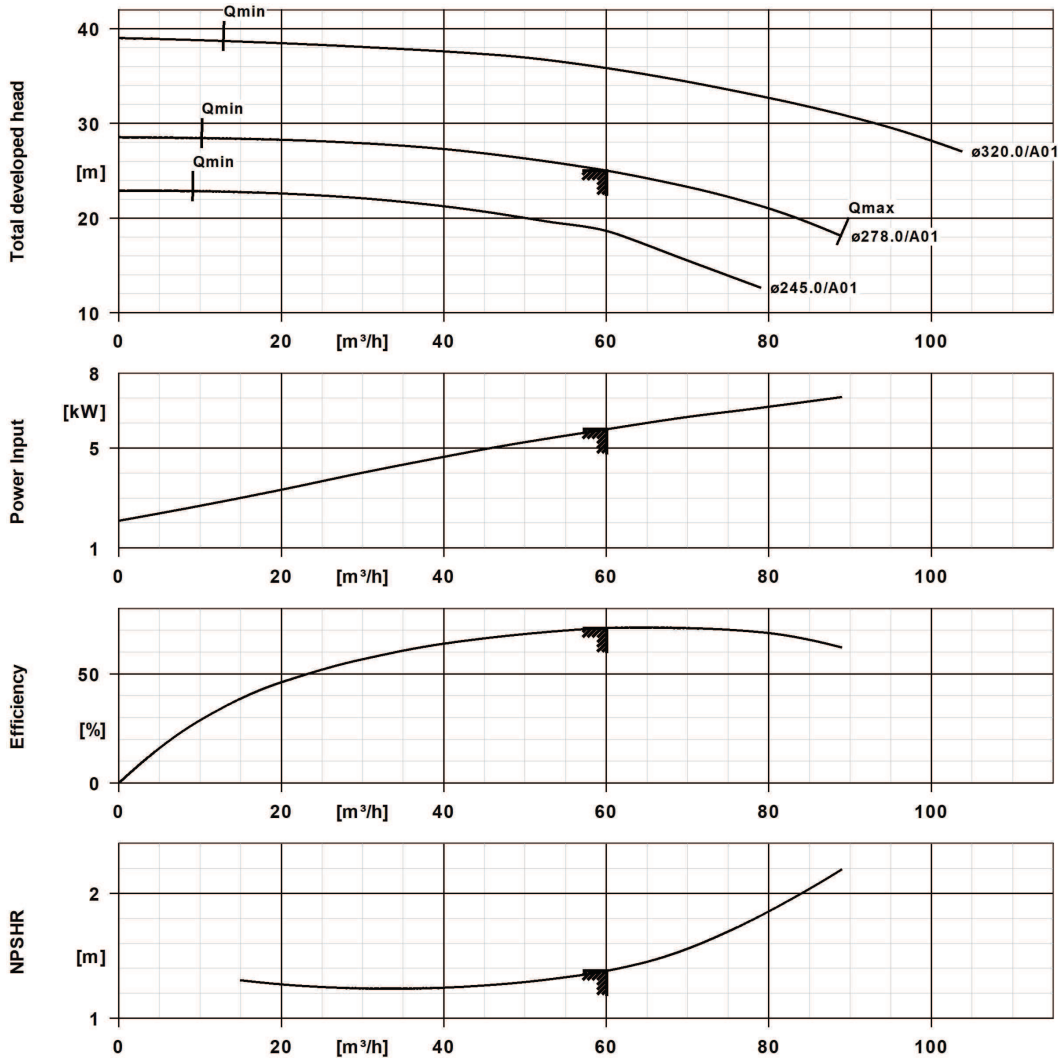

Curve Data

Pump speed	1.474 1/min	Efficiency Pump	71 %
Density Fluid handled	998 kg/m ³	Minimum efficiency index MEI	0,7
Kinematic viscosity Fluid handled	1 mm ² /s	Maximum power input at duty point	5,75 kW
Flow rate	60 m ³ /h	NPSH required	1,38 m
Head	25 m	Hydraulic impeller diameter	277,7 mm
		Hydraulic calculation according to standard/ class	EN ISO 9906 Class 3B

Etabloc 080-065-315 GB
 ETB 080-065-315-GBKBV11 WSFDN4HHB

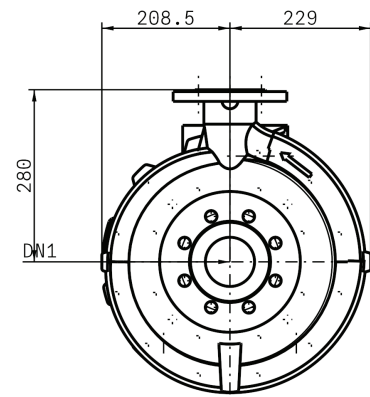
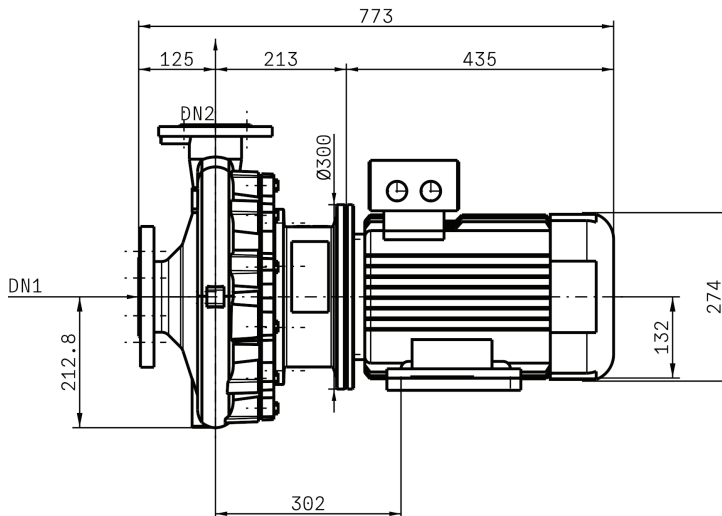
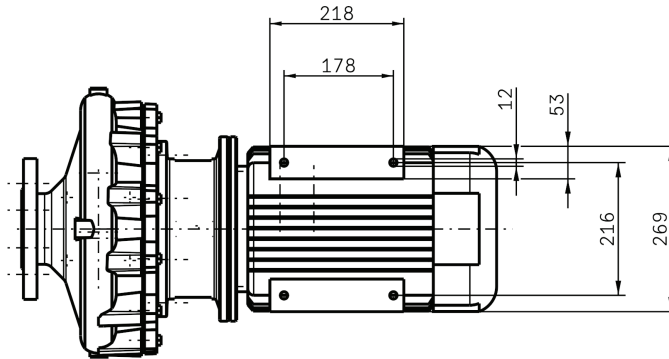

Drawing is not to scale.

Dimensions are given in mm

Motor

Motor manufacturer	KSB's choice
Motor size	132M
Rated power Motor	7,5 kW
Number of motor poles	4
Rated speed Motor	1.465 1/min
Terminal box position of motor (looking at the motor shaft)	360 °

Connections

Nominal diameter Suction nozzle	DN 80
Suction flange bolt hole pattern as per standard	EN1092-2
Nominal diameter Discharge nozzle	DN 65
Discharge flange bolt hole pattern as per standard	EN1092-2
Nominal pressure Suction nozzle	PN 16
Nominal pressure Discharge nozzle	PN 16

Net weight

Total weight Pump	80,38 kg
Total weight Drive	68 kg
Total weight Pump set	148,4 kg



Etabloc 080-065-315 GB

ETB 080-065-315-GBKBV11 WSFDN4HHB

Connect pipelines stress-free

Plan for additional connections see extra drawing

Dimensional tolerances for shaft axis height: DIN 747

Dimensions without tolerances, middle tolerances to: ISO 2768-m

Connection dimensions for pumps: EN735

Dimensions without tolerances - welded parts: ISO 13920-B

Dimensions without tolerances - gray cast iron parts: ISO 8062-CT9